

J. S. KURTZ.

LATHE FOR TURNING INSULATOR PINS, &c.

No. 267,434.

Patented Nov. 14, 1882.

Fig. 2.

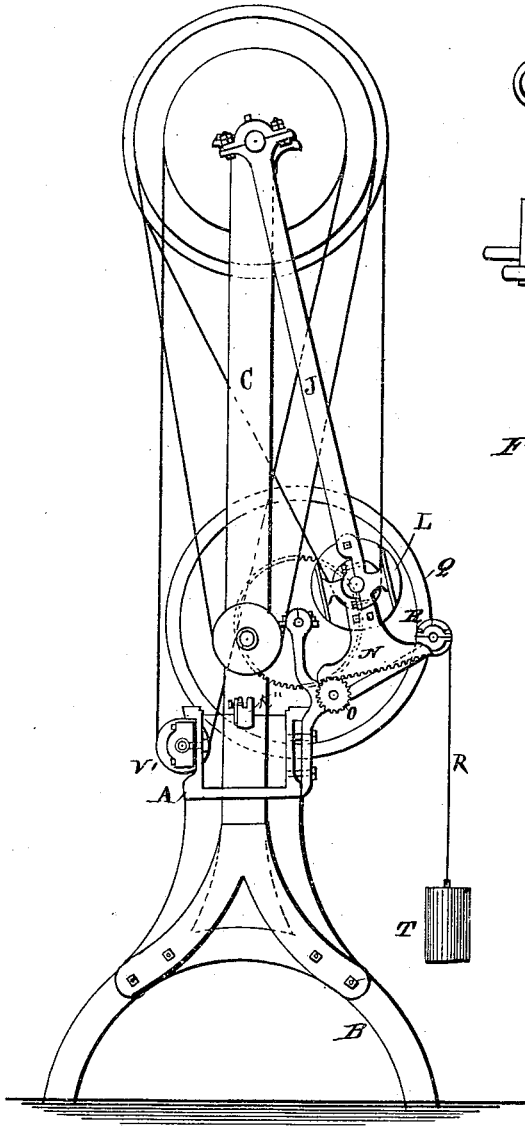

Fig. 3.

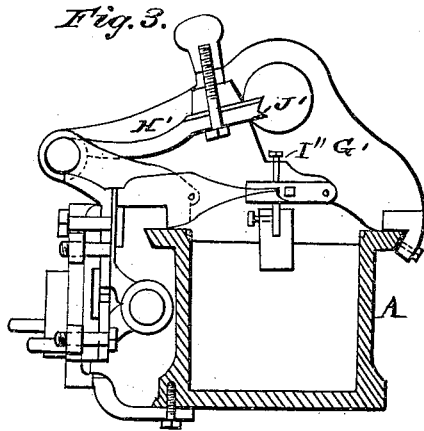
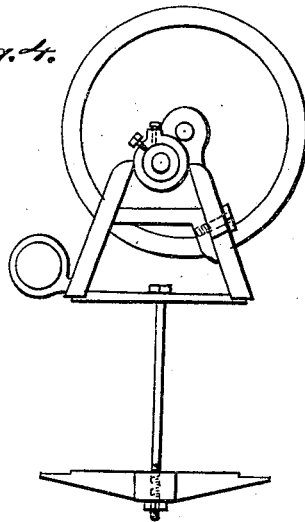

Fig. 4.



WITNESSES

Mrs. L. Dieterich
F. C. Dieterich

INVENTOR

Jacob S. Kurtz

By J. J. Johnston Attorney

J. S. KURTZ.

LATHE FOR TURNING INSULATOR PINS, &c.

No. 267,434.

Patented Nov. 14, 1882.

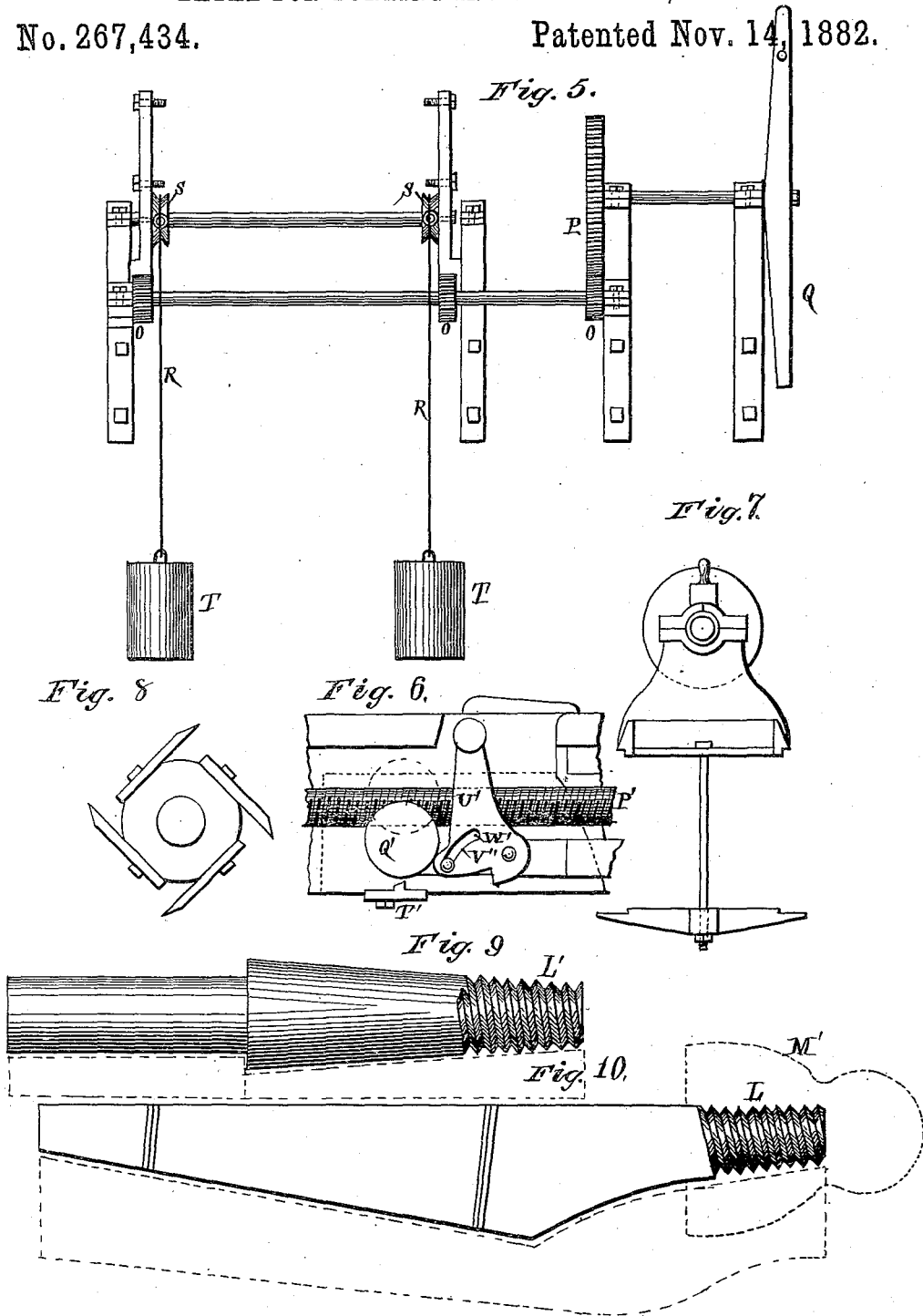

WITNESSES

Wm. G. Dieterich
F. C. Dieterich

INVENTOR

Jacob S. Kurtz

By J. J. Johnston Attorney

UNITED STATES PATENT OFFICE.

JACOB S. KURTZ, OF ALLEGHENY, PENNSYLVANIA.

LATHE FOR TURNING INSULATOR-PINS, &c.

SPECIFICATION forming part of Letters Patent No. 267,434, dated November 14, 1882.

Application filed May 24, 1882. (No model.)

To all whom it may concern:

Be it known that I, JACOB S. KURTZ, of Allegheny, in the county of Allegheny and State of Pennsylvania, have invented a new and useful Improvement in Machines for Making Insulator-Pins and Insulator-Brackets; and I do hereby declare that the following is a full, clear, and exact description thereof, reference being had to the accompanying drawings, and to the letters of reference marked thereon.

My invention relates to an improvement in machines for making insulator-pins and insulator-brackets; and it consists in the mechanism hereinafter described for forming the insulator pin or bracket and cutting the screw-thread thereon at a single and continuous operation, the operation of which mechanism will hereinafter more fully and at large appear.

To enable others skilled in the art with which my invention is most nearly connected to make and use it, I will proceed to describe its construction and operation.

In the accompanying drawings, which form part of my specification, Figure 1 is a front elevation of my improvement in machines for making insulator-pins and insulator-brackets. Fig. 2 is an end elevation of the same. Fig. 3 is a transverse and vertical section at line xx of Fig. 1. Figs. 4, 5, 6, 7, and 8 are detail views. Fig. 9 is a side elevation of an insulator-pin. Fig. 10 is a side elevation of an insulator-bracket.

In the accompanying drawings, A represents the frame of the machine, from the legs B B of which project upward supports C C for the counter-shaft D, upon which is a tight pulley, E, and loose pulley F, and also pulleys G H I.

Upon the shaft D is pivoted a pendant, J, in the lower end of which is pivoted a shaft, K, upon which is secured a cutter-head, L, furnished with cutters, the cutting-edge of which in form corresponds to the contour of the insulating pin or bracket, the outline of said cutter being indicated by dotted lines in Figs. 9 and 10. The shaft K is also furnished with a driving-pulley, M.

To each side of the pendant J is secured a toothed segment, N, the teeth of which mesh into the teeth on the periphery of the wheels O, which mesh into a wheel, P, on the shaft of which is a handle, Q. To each of the segments is attached a cord, R, which pass over

grooved pulleys S, to the lower end of which cords are attached weights T for drawing back the pendant J, thereby making the cutting-head inoperative.

On the frame A is a spindle-head, U, in suitable bearings of which is pivoted the spindle V, which spindle V is armed with driving-pulley W, said spindle being adapted at its inner end to receive a detachable centering-piece, X. On the other end of the frame A is a head, A', having a movable socket, B', in which is placed a detachable centering-piece, C', which centering-piece revolves in socket B', which socket is moved horizontally and longitudinally by means of the screw F'.

On the frame A is a carriage, G', having a pivoted cutter-holder, H', in which is secured a cutter, J', for cutting the screw-threads upon the insulator pin or bracket, as shown at L' in Figs. 9 and 10, the dotted lines M' representing the ordinary glass insulator when placed thereon. The cutter-holder H' travels over a guide or form, N', for giving the desired size and form of the screw-thread upon the insulator pin or bracket. To the carriage G' are pivoted at O' two halves of a nut, I', the bore and threads of which are adapted to the screw-threads of the feed-screw P', the lower half of the nut I' being furnished with a weight, Q', for holding said halves of the nut out of gear with the screw P', which is unshipped by the pendant U' coming in contact at S' with the adjustable stop T', the pivoted ends of said nut being coupled, as indicated at H'', so that in raising the lower half of the nut I' to bring it into gear the upper half of the nut I' will be lowered and brought into gear at the same time. The pendant U' is furnished with a curved slot, V'', in which moves a pin, V', which, when in the position shown in Fig. 1, the halves of the nut I' I' will be out of gear; but when the weight Q' is raised, as indicated by the dotted lines, the pin V', which moves in the curved slot V'', will be at W'. The feed-screw P' is journaled in suitable bearings, as indicated at X' X' X', and on the outer end of said feed-screw is a driving-pulley, Y'.

To the carriage G' is attached a cord, A'', which passes over a grooved pulley, B'', on the lower end of which cord is attached a weight, C'', which weight is for the purpose of carrying back the carriage G' when the two

halves of the nut I' I' are unshipped from the feed-screw P', which unshipping of the nut will cause the upper half of it, through the medium of the pin I'', to raise up the cutter-holder H', so that the cutter will clear the screw-thread cut on the insulator pin or bracket, which carriage, in its backward movement, strikes against an elastic buffer, D'', which elastic buffer prevents undue jarring of the carriage G' and the several parts connected therewith.

The form of the cutting end of the cutter J' for cutting the screw-threads on the insulator pins or brackets is clearly indicated in Fig. 3.

E'', F'', and G'' in Fig. 1 represent belts. The spindle V and detachable center C' should travel at about two thousand revolutions per minute, and the feed-screw P' should travel at about the same speed—that is to say, two thousand revolutions per minute—and the cutting-head L should travel at a speed of about three thousand revolutions per minute. These speeds I have found to produce a good result; but I wish it distinctly understood that I do not confine myself to said speeds, but leave the speed of said parts to the skill and good judgment of the mechanic.

From the foregoing description, and by reference to the accompanying drawings, the skillful mechanic will readily understand the construction of my improvement in machines for making insulator pins and brackets, and the relation that the several parts bear to each other. I will therefore proceed to describe the operation, which is as follows: Blanks of wood of suitable length and diameter are cut from a board or plank or other form of timber. It is then, through the medium of the centers X and C', properly centered in the machine and secured to said centers through the medium of the hand-wheel F⁴ and screw E⁴ moving the sockets B' forward, causing the center C' to travel toward the center X. The blank thus secured is then caused to be revolved by power applied to the pulley E on the counter-shaft D, which will cause the pulley H on said shaft, through the medium of the belt F'', to revolve the pulley W and mandrel V, with its center X, which will revolve the center C' in the socket B', both of the centers X and C' being "live centers." The pulley G on the counter-shaft D, through the medium of the belt E'', will revolve the pulley M, shaft K, and cutter-head L, and the pulley I on the counter-shaft D will, through the medium of the belt G'', revolve the pulley Y' and feed-screw P'. The operator then, by means of the hand-wheel Q, wheel P, wheels O,

and toothed segments N, brings forward the pendant J, bringing the cutter on the cutter-head L in contact with the revolving blank, the cutting-edge of the cutter being at an acute angle to the axis of the blank, which arrangement of cutting-edges prevents undue splintering or tearing of the wood. The pendant J should be controlled by an adjustable stop, as indicated at K'', to adjust the action of the cutting-head to the desired diameter of the insulator pin or bracket. Just as the cutters on the cutter-head are finishing their work the operator raises the weight Q', which ships the two halves I' I' of the nut into gear with the feed-screw P', during which operation of shipping the pendant J is drawn back by the weights T, making the cutter inoperative prior to any forward movement of the carriage G'. The shipping of the two halves of the nut into gear lowers the cutter-holder H', bringing the cutter J' for forming the screw-thread upon the insulator pin or bracket in contact with the partially-formed insulator pin or bracket, thereby causing the cutter to form the screw-thread by the cutter-holder traveling over the guide N', which guide gives the desired depth and form of screw, the forward movement of the carriage G' bringing the point S' of the pendant R' in contact with the adjustable stop T', which will unship the two halves I' I' of the nut, the upper half, through the medium of the pin I'', raising the cutter-holder H', so that the cutter J' clears the thread which it has cut. The weight C'' at this point draws back the carriage G', and as the carriage moves back the operator, through the medium of the hand-wheel F⁴, draws back the socket B' and its center C', which will allow the finished insulator pin or bracket to drop or be removed from the machine to give place to another blank.

Through the medium of the machine hereinbefore described insulator-pins or insulator-brackets may be constructed with ease, facility, and at diminished cost.

Having thus described my improvement, what I claim as of my invention is—

In a machine for making insulator-pins or insulator-brackets, the combination of the pendant J, having cutter-head L, carriage G', having cutter-holder H' and cutter J', and their operating mechanism, substantially as hereinbefore described.

JAC. S. KURTZ.

Witnesses:

A. C. JOHNSTON,
T. D. D. OURAND.